

Factory Automation

GIZA
SYSTEMS
we integrate



ARIA
TECHNOLOGIES

Who We Are

ARIA Technologies, a Giza Systems subsidiary, is a responsible and committed full service solutions provider and systems integrator delivering turnkey automation and energy optimization solutions to manufacturing companies across the MENA region. Partnering with world pioneers in robotics and automation, ARIA Technologies is a certified robot system integrator leading the digitalization of industrial technology.

What We Do

We work with our customers to create genuine and responsible value through offering state-of-the-art technologies for sustainable, efficient and resilient industries to support growth, development and the environment. Our services include automation systems, industrial IoT and energy optimization.

Our products and system integration solutions enable our customers to reduce costs; and increase productivity, flexibility and precision of day-to-day operations. Our core competencies include design and implementation of solutions with programmable controllers, information systems, drives, motion control and different robotic systems integration.

Our industrial IoT platform provides our customers with a number of capabilities including predictive maintenance, performance monitoring and energy efficiency solutions. IIoT delivers countless benefits ranging from real-time monitoring of performance and quality control to equipment maintenance and safety.

In addition to our industrial IoT platform, we also offer energy optimization solutions. We adopt the latest in cutting-edge technologies to reduce energy consumption, costs, and carbon footprint. Our team of experts offers customized re-tuning energy optimization and renewable energy integration solutions to transform infrastructures and support resilient sustainable industries.

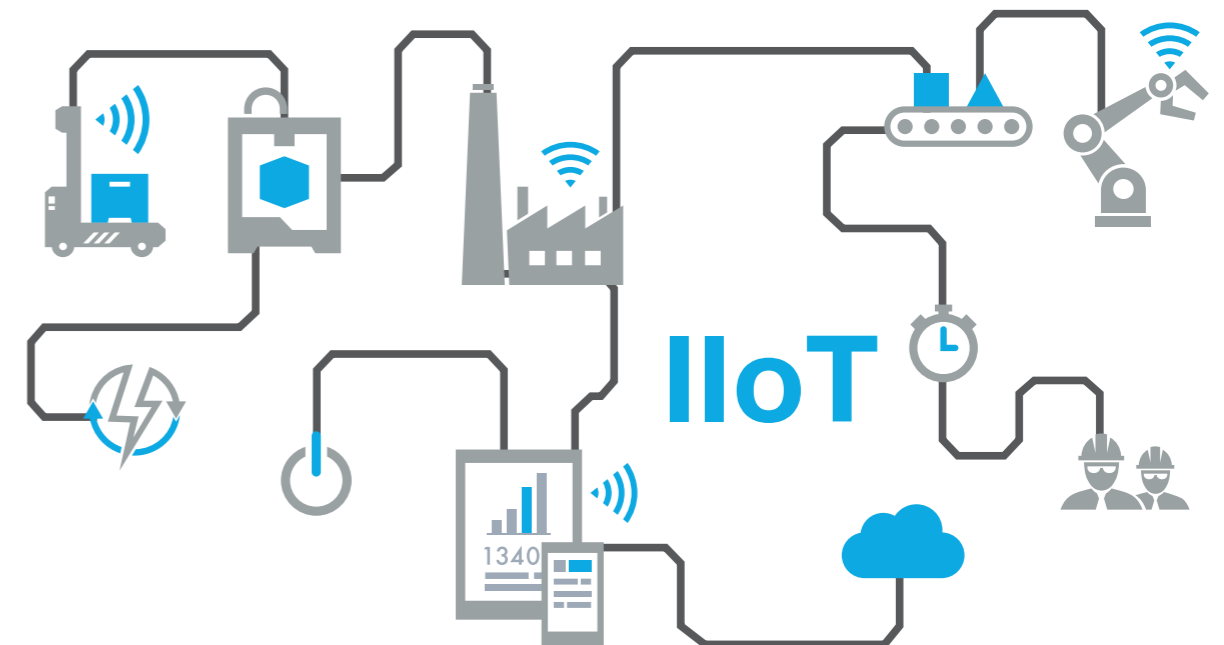

Target Sectors

ARIA Technologies, as a subsidiary of Giza Systems, is uniquely positioned to fulfill the needs of the local and regional markets for factory automation.

Our services and solutions support our customers in achieving manufacturing, environmental and financial benefits and cater to a number of sectors including:

- Home & Electric Appliance Industries
- Plastic & Packaging Industries
- Cosmetics Industries - Food & Beverage Industries
- Automotive Industries - Defense Industries
- Medical & Pharmaceutical Industries - FMCG Industries
- Home Appliance Manufacturing
- Mold & Die Industries

Offices

- Headquarter: 5th settlement, New Cairo, Egypt
- Factory: Plot No. 813, Industrial Zone, Third Settlement, New Cairo, Egypt
- KSA branches: Riyadh, Al-Khobar and Jeddah
- UAE branch: Dubai

Quality

Giza Systems strives to integrate quality in all its processes to ensure adherence to the best standards and practices. Giza Systems has received the ISO 9001:2008, ISO 14001:2004, and OHSAS 18001:2007.



Factory Automation

We specialize in factory automation solutions to optimize manufacturing operations. We work with our clients, in various scopes and capacities, based on their needs and manufacturing requirements.

Our core competencies include design and implementation of solutions with programmable controllers, information systems, drives, motion control and different robotic systems integration.

Our different factory automation solutions cater to the digitalization of the manufacturing process, providing our customers with the ability to:

- ✓ Increase productivity
- ✓ Lower manufacturing costs
- ✓ Enhance flexibility and repurposing
- ✓ Improve precision and accuracy
- ✓ Ensure highest quality standards and consistency
- ✓ Increase worker safety

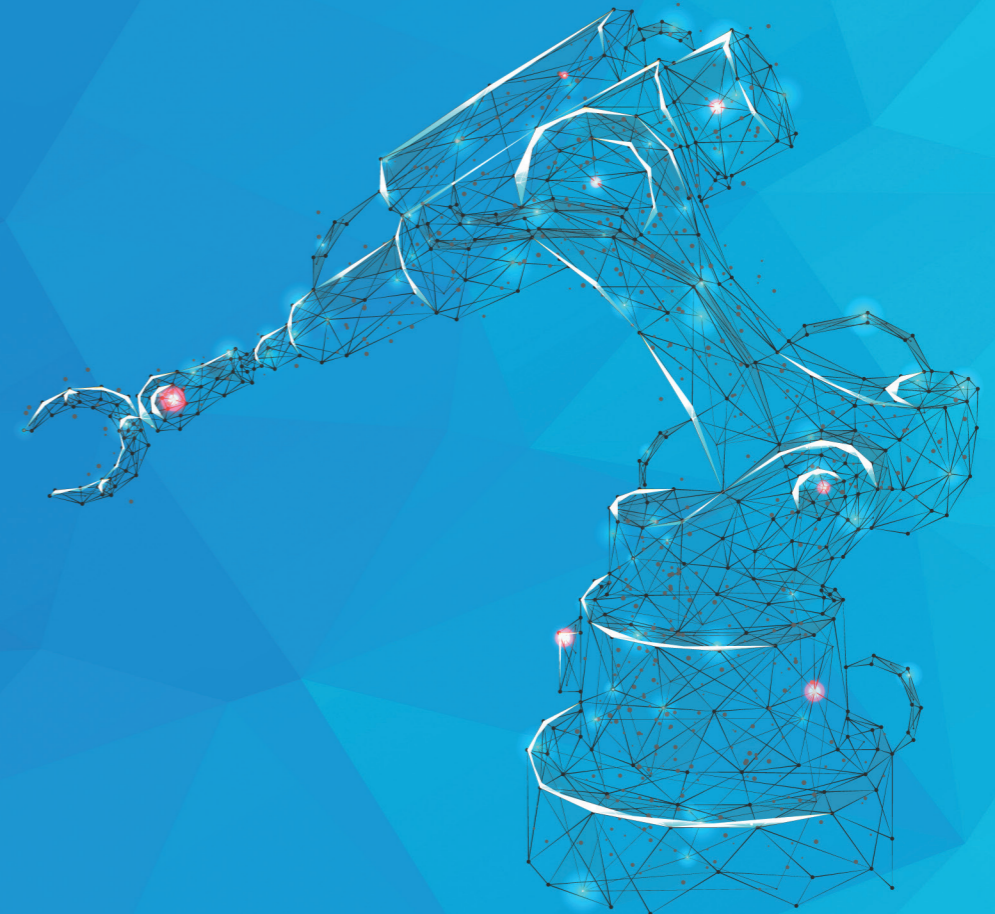

Linear Robot
Original Equipment Manufacturer

Industrial Robot
System Integrator

Smart Vision
System Integrator

Automation Retrofit
System Integrator



Energy Efficiency
Industrial IoT

Predictive Maintenance
Industrial IoT

Performance Monitoring
Industrial IoT

Energy Audits
ISO 50001 - 2018

Energy Optimization
ISO 50001 - 2018

Renewable Energy
System Integrator

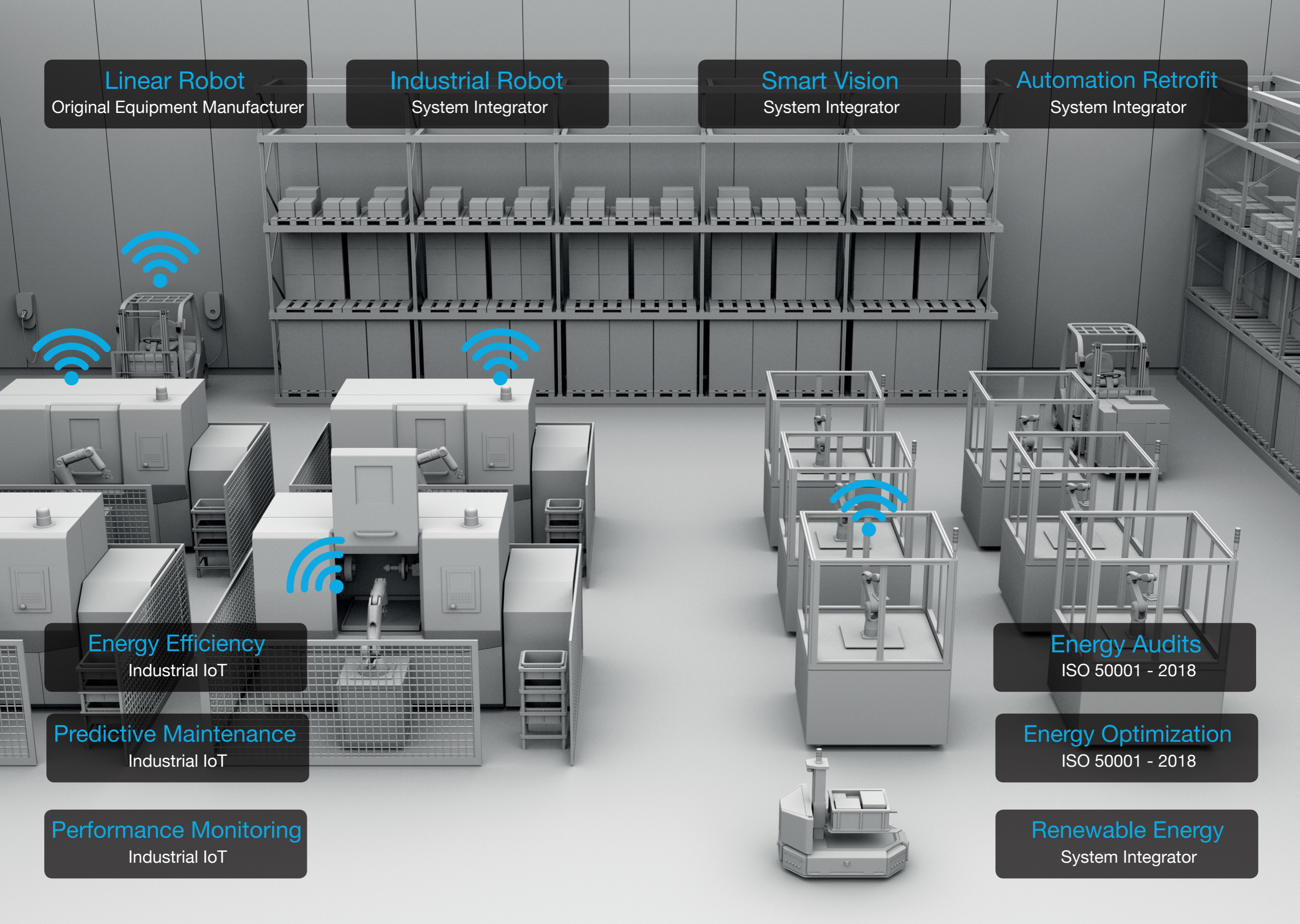

Linear Robots Partner to **BECKHOFF** Germany

Our in-house developed line of linear robots allow us to offer our customers full systems integration, full design and full manufacturing capabilities.

We custom make your linear robot based on the specific application needed for your manufacturing operation.

ARIA 200C Linear Robot

Model	Ton	Traverse Stroke	All Driven	Crosswire Stroke	Max. Loading	Vertical Stroke	Net Weight
200 C	700: 1800T	2,200 mm	ServoMotor BECKHOFF	900 mm	40 Kg	1,000 mm	1,500 Kg

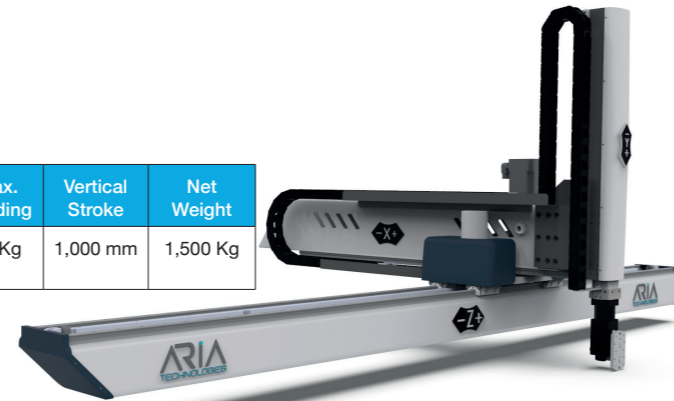

Model	A	B	C
200 C	2,200 mm	900 mm	1,000 mm

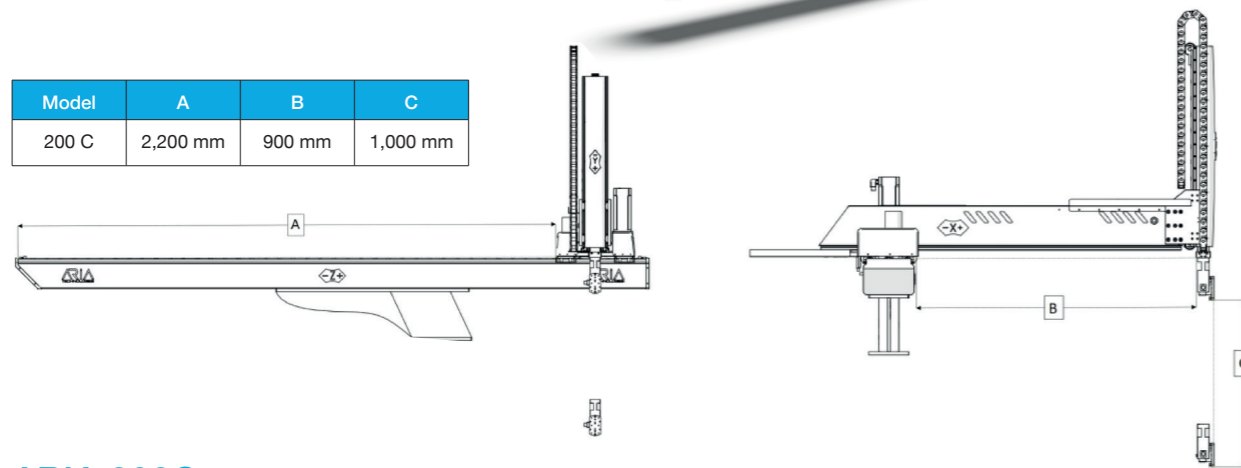

ARIA 300C Linear Robot

Model	Ton	Traverse Stroke	All Driven	Crosswire Stroke	Max. Loading	Vertical Stroke	Net Weight
300 C	2000: 3000T	3,200 mm	ServoMotor BECKHOFF	1,400 mm	60 Kg	1,500 mm	2,000 Kg

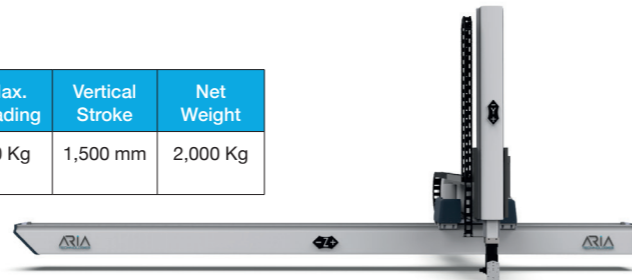

Model	A	B	C
300 C	3,200 mm	1,400 mm	1,500 mm

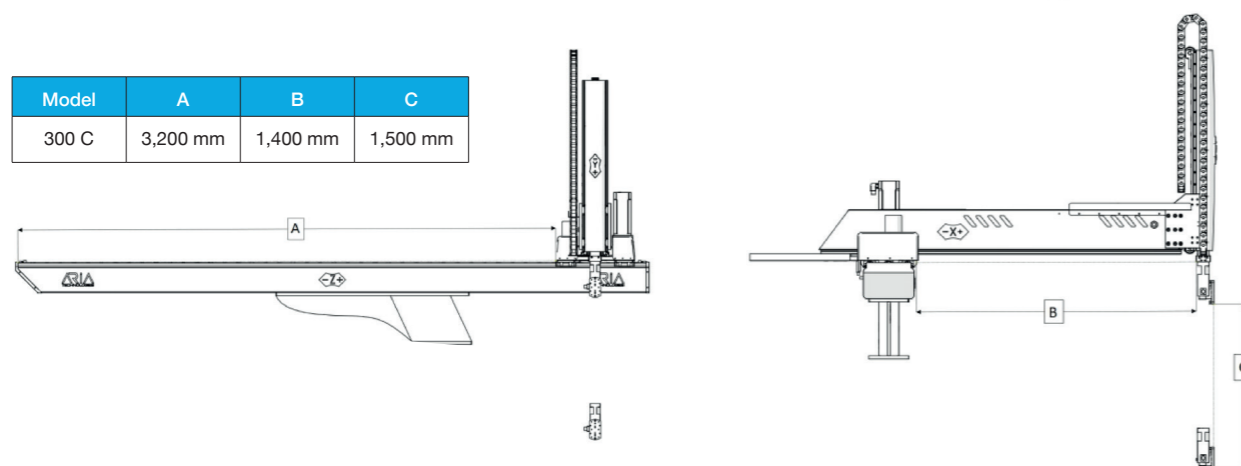

ARIA 300G Linear Robot Gantry type

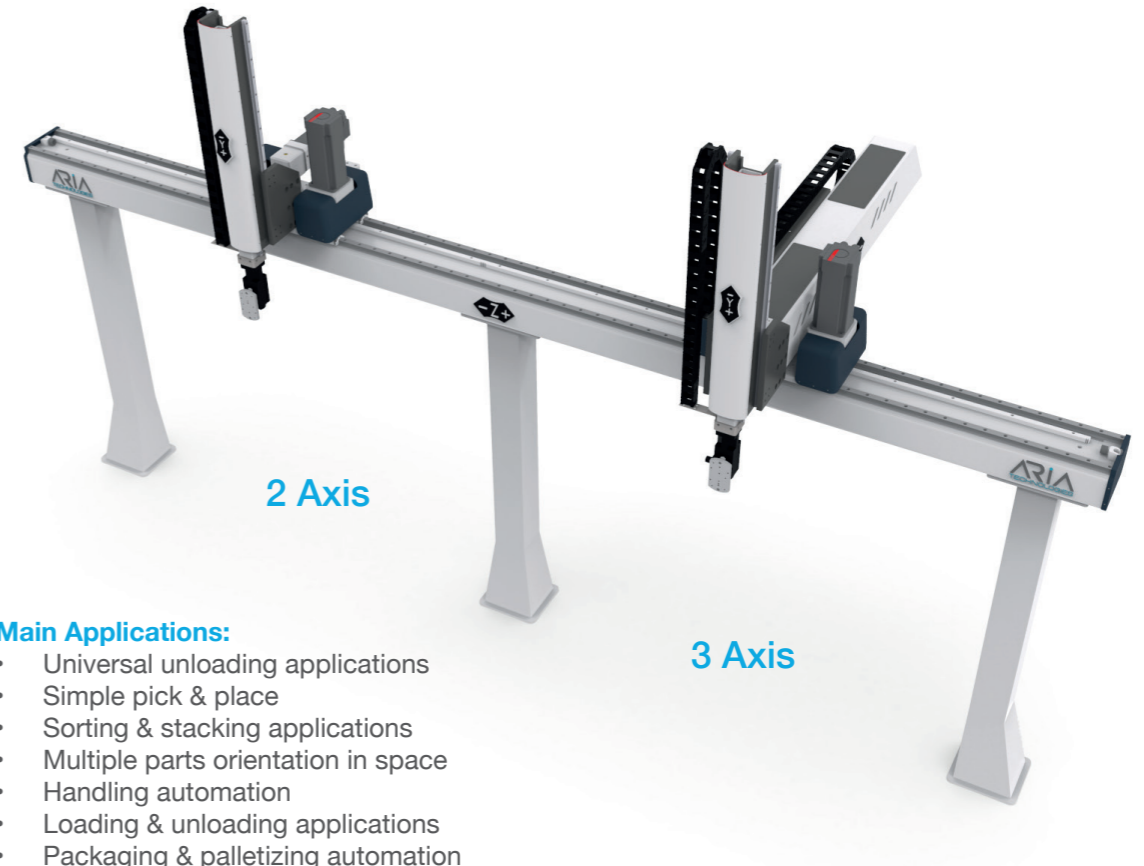

Main Applications:

- Universal unloading applications
- Simple pick & place
- Sorting & stacking applications
- Multiple parts orientation in space
- Handling automation
- Loading & unloading applications
- Packaging & palletizing automation
- Inspection automation

Robot System Controller:

- Euro-map interface to the production line
- Clear and easy programming with sequence editor
- Consistent operating philosophy for robot and machine sequences
- Simple programming for various applications
- Teach-in Programming
- Safe home position

End-of-Arm-Tooling (EOAT) Design and Build Service

From the simplest to the most complex EOAT, ARIA Technologies specializes in designing and building customized End-of-Arm-Tooling at competitive pricing.

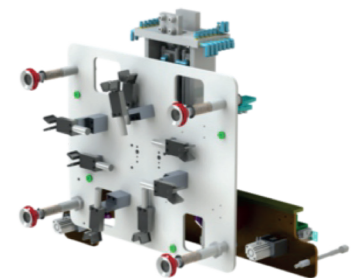

Certified Industrial Robot System Integrator

Partner to **MITSUBISHI AUTOMATION** & International Manufacturers

We deliver full systems integration to our clients in addition to design and manufacturing to tailor end of arm tools (end effectors) and manufacturing cells.

Our team of highly qualified experts provides turnkey robotic automation solutions to manufacturing companies across the region.

Our different robotic solutions cater to the digitalization of the manufacturing process, providing our customers with the ability to:

- ✓ Increase productivity
- ✓ Lower manufacturing costs
- ✓ Enhance flexibility and repurposing
- ✓ Improve precision and accuracy
- ✓ Ensure highest quality standards and consistency
- ✓ Increase worker safety

Main Applications:

- Paint / polish / sanding process
- Simple sorting & stacking applications
- Cutting / trimming process
- Welding / sealant / bonding applied process
- Material handling / palletizing
- Assembly cell (independent/in-line)
- Machining process
- Finished products inspection with smart camera integration



Smart Vision

Partner to **COGNEX**

ARIA Technologies is a system integrator. Cognex advanced machine vision & industrial systems, delivering instant improvements to the process by enabling products to be made without defects and at lower cost.

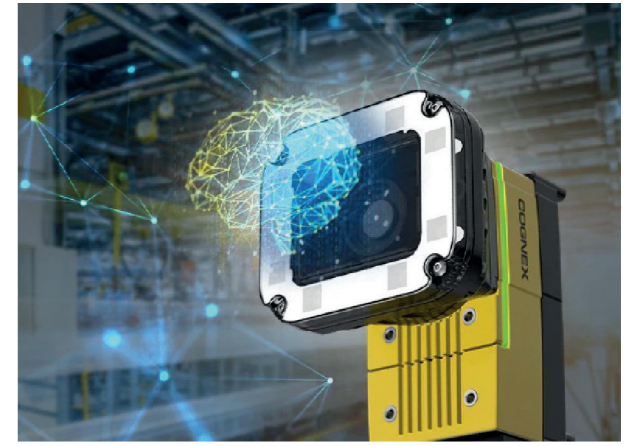

Factory Automation Retrofit and Modernization

Scope of services include:

- Mechanical issues and functionality
- Performance of repeat-ability tests
- Integration and programming of the new automation systems
- Safe powering-up of systems and controllers
- Electrical issues and functionality
- Full manufacturer warranty applies



Industrial Internet of Things (IIoT)

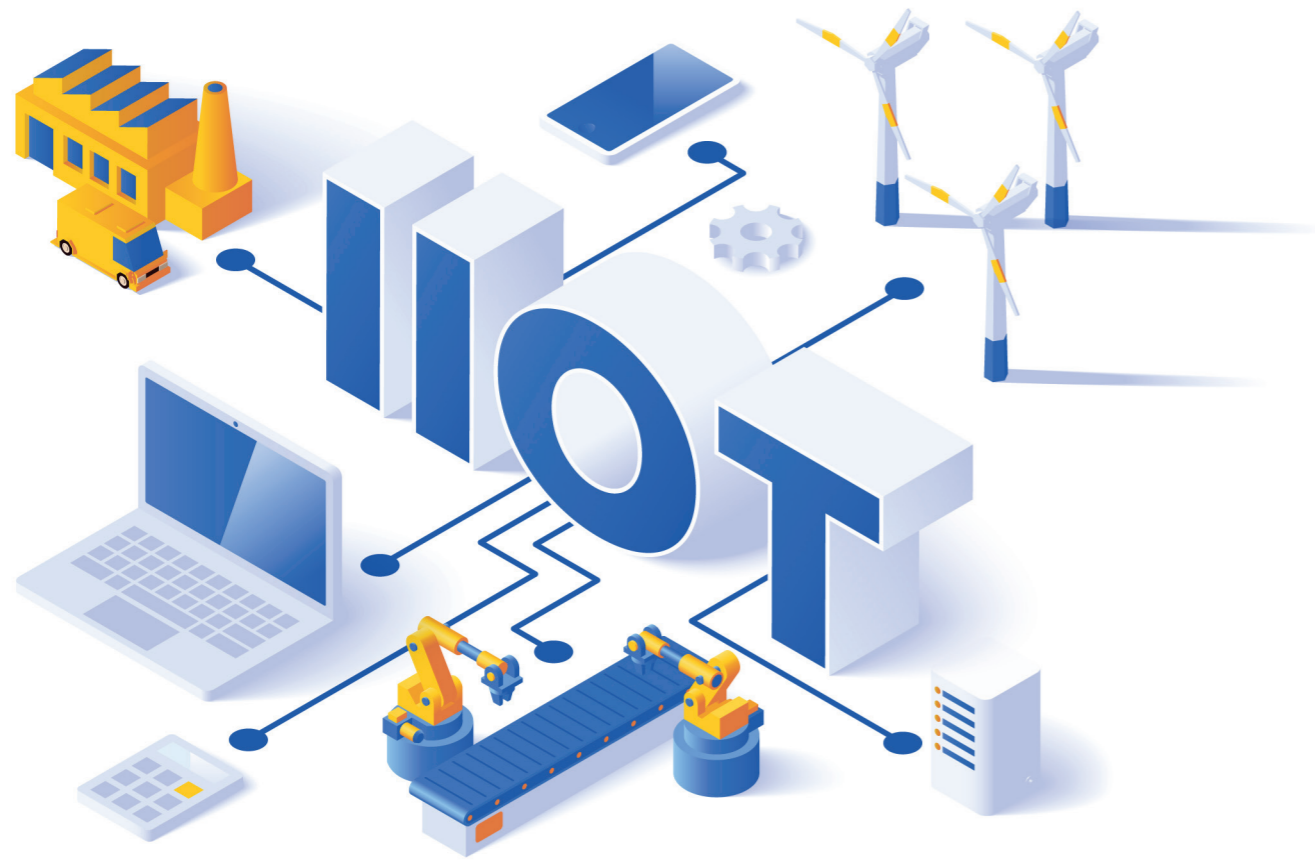

ARIA
TECHNOLOGIES



Industrial IIoT

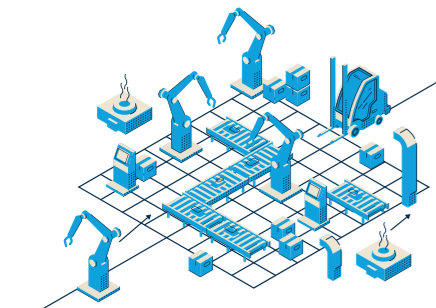

Factory Floor Sensors



Energy Efficiency Monitoring



Client Device

Predictive Maintenance

Predictive maintenance (PdM) techniques are designed to help determine the condition of equipment in order to predict when maintenance should be performed or possible breakdowns. Predictive maintenance promises cost savings over routine or time-based preventive maintenance, as the tasks are performed only when warranted.

Predictive maintenance measures include:

Vibration / Pressure / Temperature / Flow Rate / Weight / Torque / Speed / Stroke / Humidity / Level Sensors.



Performance Monitoring

Machine/robot real-time performance monitoring generates data that can be used to evaluate machine operational conditions and efficiency, needed for required perfective maintenance (PdM) and others smart factory applications.

Performance Monitoring Benefits:

- ✓ Reducing maintenance costs
- ✓ Maximizing production
- ✓ Optimizing spare parts inventory
- ✓ Extending machinery lifetime
- ✓ Generating accurate data for driving factory/product development



Energy Efficiency Monitoring

Energy efficiency (EE) is a critical indicator in the manufacturing industry due to the rising cost of energy and the increasing environmental regulations addressing global concerns about climate change. Manufacturing companies are looking to monitor aggregated energy consumption and ensure real-time visibility of EE on factory floors.



Energy Monitoring Benefits:

- ✓ Reduce energy spending
- ✓ Comply with governmental regulations
- ✓ Optimize asset maintenance
- ✓ Cut operational expenses
- ✓ Gain visibility for energy consumption
- ✓ Identify malfunctions in real-time and prevent them
- ✓ Predict consumption and plan accordingly
- ✓ Minimize carbon emissions
- ✓ Integrate green energy

Egypt

New Cairo

Head Office

Plot No. 176, Second
Sector,
City Center, P.O. Box 157
New Cairo 11835,
Egypt

☎ : +202 26146000 / 6111

☎ : +202 26146001

✉ info@ariatechnologies.com

Factory

Plot No. 813,
3rd District, Industrial Zone,
New Cairo, Egypt

☎ : +202 25734652

Saudi Arabia

Riyadh

Giza Arabia
Rosayes Business
Center,
P.O. Box 67765,
Riyadh 11517,
KSA

☎ : +966 1 460 2890

☎ : +966 1 460 2892

UAE

Dubai

Giza Systems DMCC
Fortune Tower - Office
No. 1306 - 13th Floor,
Dubai,
UAE

© 2020 ARIA Technologies. All rights reserved.

The logo of ARIA Technologies is a registered trademark.

ARIA Technologies, a Giza Systems subsidiary, is a responsible and committed full service solutions provider and systems integrator delivering turnkey automation and energy optimization solutions to manufacturing companies across the MENA region. Partnering with world pioneers in robotics and automation, ARIA Technologies is a certified robot system integrator leading the digitalization of industrial technology.